

IMPORTANT NOTICE

All rights to this manual are owned solely by SATEL OY (referred to in this user guide as SATEL). All rights reserved. The copying of this manual (without the written permission from the owner) by printing, copying, recording or by any other means, or the full or partial translation of the manual to any other language, including all programming languages, using any electrical, mechanical, magnetic, optical, manual or other methods or devices is forbidden.

SATEL reserves the right to change the technical specifications or functions of its products, or to discontinue the manufacture of any of its products or to discontinue the support of any of its products, without any written announcement and urges its customers to ensure, that the information at their disposal is valid.

SATEL software and programs are delivered "as is". The manufacturer does not grant any kind of warranty including guarantees on suitability and applicability to a certain application. Under no circumstances is the manufacturer or the developer of a program responsible for any possible damages caused by the use of a program. The names of the programs as well as all copyrights relating to the programs are the sole property of SATEL. Any transfer, licensing to a third party, leasing, renting, transportation, copying, editing, translating, modifying into another programming language or reverse engineering for any intent is forbidden without the written consent of SATEL.

SATEL PRODUCTS HAVE NOT BEEN DESIGNED, INTENDED NOR INSPECTED TO BE USED IN ANY LIFE SUPPORT RELATED DEVICE OR SYSTEM RELATED FUNCTION NOR AS A PART OF ANY OTHER CRITICAL SYSTEM AND ARE GRANTED NO FUNCTIONAL WARRANTY IF THEY ARE USED IN ANY OF THE APPLICATIONS MENTIONED.

Salo, FINLAND 2004

RESTRICTIONS ON USE

SATELNODE X8S receiver has been designed to operate on frequency ranges, the exact use of which differs from one region and/or country to another. The user of a radio modem must take care that the device is not operated without the permission of the local authorities on frequencies other than those specifically reserved and intended for use without a specific permit.

In addition, please pay attention to the possible local restrictions stated by the national radio authorities.

PRODUCT CONFORMITY

Hereby, SATEL Oy, declares that this SATELNODE X8S alarm transmitter is in compliance with the essential requirements and other relevant provisions of Directive 1999/5/EC. Therefore the equipment is labelled with the following CE –marking.



WARRANTY AND SAFETY INSTRUCTIONS

Read these safety instructions carefully before using the product:

- Warranty will be void, if the product is used in any way, which is in contradiction with the instructions given in this manual, or if the housing of the radio modem has been opened or tampered with.
- The radio modem is to be used only on frequencies allocated by local authorities and without exceeding the given maximum allowed output power ratings. SATEL is not responsible, if any products manufactured by it are used in unlawful ways.
- The devices mentioned in this manual are to be used only according to the instructions described in this manual. Faultless and safe operation of the devices can be guaranteed only if the transport, storage, operation and handling of the devices is appropriate. This also applies to the maintenance of the products.
- To prevent damage to both the radio modem and any terminal devices must always be switched OFF before connecting or disconnecting the serial connection cable. It should be ascertained that different devices used have the same ground potential. Before connecting any power cables the output voltage of the power supply should be checked.

TABLE OF CONTENTS

IMPORTANT NOTICE	1
RESTRICTIONS ON USE	2
PRODUCT CONFORMITY	3
WARRANTY AND SAFETY INSTRUCTIONS.....	4
TABLE OF CONTENTS.....	5
1 FUNCTIONAL DESCRIPTION	8
1.1 Introduction	8
1.2 Reception	8
1.3 RS-232 interface	9
1.4 Output lines.....	9
1.5 Acknowledgement of the alarms	9
1.6 Link monitoring	10
2 INTERFACE.....	11
2.1 D15-connector.....	11
2.2 Led indicators.....	11
3 CONFIGURATION.....	12
3.1 Configuration procedure.....	12
3.2 Modifying setup: menu system	13
3.3 Modifying setup: parameters	15
3.4 Output definition	16
4 RS232 PROTOCOLS	18
4.1 Satel SIA X8S protocol	18
4.2 Satel SIA X3S protocol	22
5 SATELNODE X8S SYSTEM DESIGN	25
6 INSTALLATION.....	27
6.1 Mounting.....	27
6.2 Cable connections.....	27
6.3 Antenna installation	28

7 TECHNICAL SPECIFICATIONS OF SATELNODE X8S 30

8 OTHER RELATED PRODUCTS BY SATEL..... 31

 8.1 SATELCODE 8i alarm transmitter 31

9 CHECK LIST 32

SATELNODE X8S RADIO RECEIVER

SATELNODE X8S is a versatile radio receiver which receives the messages sent by various SATEL alarm transmitters. SATELNODE X8S processes messages and writes them on the RS-232 interface. The device includes also eight relay outputs (other alternatives also possible) which can be set to react on specific messages or events. SATELNODE X8S consists of the VHF receiver and the processor logic, housed in a compact, strong aluminium casing.

SATELNODE X8S is an ideal product for a wide range of wireless alarm transfer applications. Together with the 4W SATELCODE 8i transmitter it easily provides radio connections over 20 kilometers. The excellent noise performance of the VHF receiver makes this possible. SATELNODE X8S suits equally well both in a one transmitter system and a large system with up to 64000 transmitters. The user programmable features ease the system development considerably.

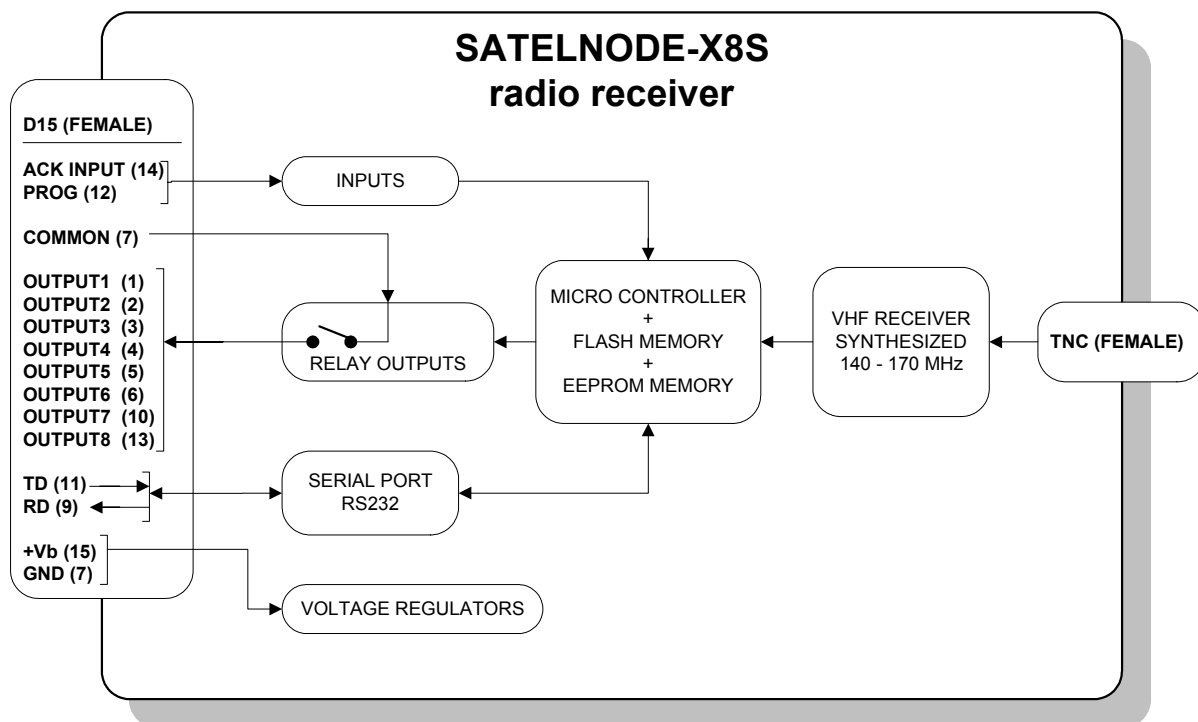

Figure A. SATELNODE X8S Block Diagram

1 FUNCTIONAL DESCRIPTION

1.1 Introduction

SATELNODE X8S is a sensitive VHF narrowband FM receiver, designed for use with the alarm transmitters manufactured by SATEL. It operates on a single frequency, which can be in the range 140...170 MHz. The user can select the frequency to be used \pm 1MHz off the center frequency that is set

SATELNODE X8S requires only an antenna and a power supply to operate. Additionally, the use of an antenna filter is recommended in some cases.

SATELNODE X8S provides the RS-232 serial data interface, which data terminal equipment (DTE) is connected to.

SATELNODE X8S provides also eight outputs, which can be remotely controlled by a specific event on the transmitter side.

1.2 Reception

SATELNODE X8S receives the messages from SATEL alarm transmitters; the table below lists the different transmitters and their power levels.

<i>Table 1.1 SATELNODE X8S compatible alarm transmitters</i>	
<i>Transmitter Type</i>	<i>Transmitter Power</i>
SATELCODE-8i	4W
SATELCODE (versions including a micro controller, manufactured 1997...2003)	0,5 W
SATELCODE versions without a micro controller, so called ED transmitters that are not available any more. <i>NOTE:</i> The reception of ED transmitters is supported only by the special "ED" marked software versions of SATELNODE X8S.	0,5 W

SATELNODE X8S continuously searches for the valid start of a message. Once it is detected, the receiver receives the message. If the received message is valid, it is converted to a RS-232 message, according to the selected protocol. The converted message is then written to the RS-232 interface.

1.3 RS-232 interface

The RS-232 interface of SATELNODE X8S includes RD line (Received Data ie. the data to external equipment) and TD (Transmitted Data ie. the data from external equipment). The TD line is for programming purposes only. The parameters are: 1200, 2400, 4800, 9600, 19200, 38400 or 115200 bps (user selectable), 8 data bits, no parity.

The messages appear on the RD line. The message format depends on the protocol which can be selected in the setup. The available protocols are described in the chapter 4 *RS-232 PROTOCOLS*.

1.4 Output lines

The eight outputs become activated on specific alarm messages, which can be defined by the user in the setup. An output line is a relay contact which either connects the output pin to COMMON pin, or breaks the connection to COMMON pin.

At the startup, when the power is switched on, SATELNODE X8S switches all the outputs to their normal states (OFF). When the triggering event occurs, the corresponding output line becomes activated (ON) ie. The output connects to COMMON pin. The Chapter 3 *CONFIGURATION* describes how to define the outputs.

1.5 Acknowledgement of the alarms

If any of the output lines becomes activated by an alarm, the acknowledgement is done by connecting the LP1 input (D connector pin 3) to GND for more than 2 seconds.

The acknowledgement at any time resets all the alarm outputs back to the normal (OFF) status.

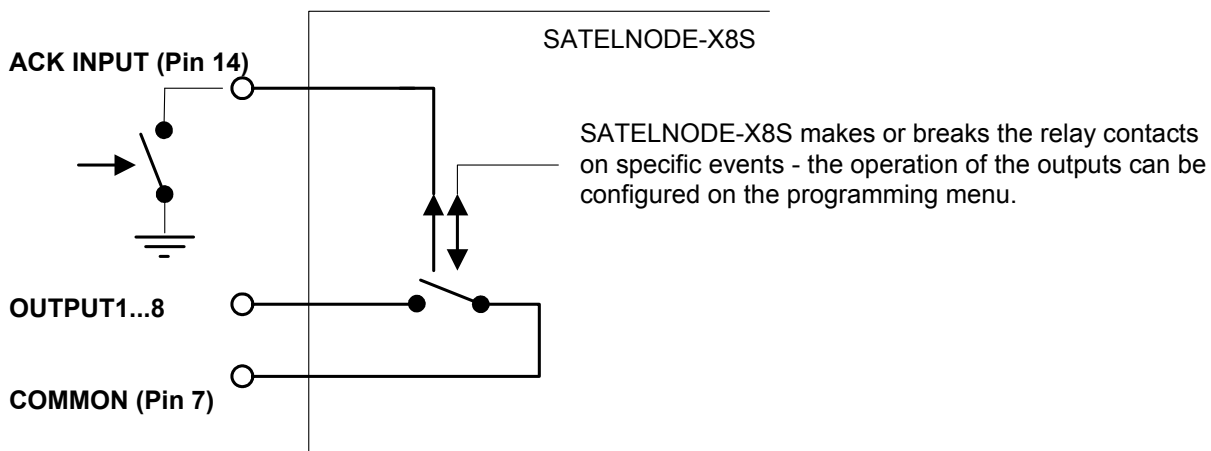

Figure 1.1 The operation of eight relay outputs of SATELNODE X8S.

1.6 Link monitoring

SATELNODE X8S can monitor the condition of the radio connection from a number of SATELCODE 8i alarm transmitters (up to 10 or 20 transmitters, depending on the software version). In other words, SATELNODE X8S is able to check if all the monitored transmitters are “alive”. In case any of the monitored transmitters fail to send their message to SATELNODE X8S at time intervals defined by user, an alarm will be triggered.

Any of the relay outputs can be configured to indicate the link failure also.

There are two modes of operation for link monitoring – *Automatic* or *User Defined*.

- *Automatic Link Monitoring* means that the SATELNODE X8S adds any received SATELCODE 8i transmitter to the list of the monitored transmitters. An alarm will be triggered if reception from one or more of the monitored transmitters is missed for the time defined by *Monitor Time* parameter.
Note: The list of monitored transmitters is empty every time the SATELNODE X8S is powered up.
- *User Defined Link Monitoring* means that the user defines the monitored SATELCODE 8i transmitters manually.

User can set the time interval (*Link Monitor Time*) in which all the monitored transmitters must be received, in order not to trigger an alarm

The Chapter 3 *CONFIGURATION* describes how to define the actual parameters of link monitoring.

2 INTERFACE

SATELNODE X8S provides two connectors for interfacing.

- Antenna is connected to the female TNC connector. Impedance is 50 ohms.
- Terminal equipment and power supply are connected to the female 15 pin D-connector.

2.1 D15-connector

Pin	Line	I/O	Level	Description
1	OUT1	In/Out	-	Output1
2	OUT2	In/Out	-	Output2
3	OUT3	In/Out	-	Output3
4	OUT4	In/Out	-	Output4
5	OUT5	In/Out	-	Output5
6	OUT6	In/Out	-	Output6
7	COMMON		-	Common pin of the relay outputs
8	GND	Gnd	GND	Operating voltage negative pole and signal ref. ground
9	RD	Out	RS232	Received Data
10	OUT7	In/Out	-	Output7
11	TD	In	RS232	Transmitted Data (used in the configuration only)
12	PROG	In	0-12V	Programming input, activated by connecting to GND
13	OUT8	Out	-	Output8
14	ACK INPUT	In	0-12V	Input for acknowledging i.e. resetting the outputs
15	+VB	Power	+12VDC	Operating voltage positive pole + 9...+14 VDC

Note: Unused pins should be left unconnected.
Note: The sum of the currents flowing through Outputs OUT1...8 can be max 1A totally.

2.2 Led indicators

LED Symbol	Indication
ON	Power is ON
RX	Receiving a message
AL	Active alarms on the output lines
LO	RSSI level indicator – Low level signal
HI	RSSI level indicator – High level signal

Note: HI and LO simultaneously shining means RSSI Medium level signal.

3 CONFIGURATION

SATELNODE X8S provides several user definable properties. SATELNODE X8S has to be reconfigured in case you need to change its operation (eg. changing RS-232 settings or setting the parameters for the operation of the outputs etc.). Refer to this chapter whenever you reconfigure your SATELNODE X8S. The reconfiguration can be done easily with a PC equipped with a terminal program. SATELNODE X8S provides a menu system; it displays the current setup information and makes the changes upon user selections. The user types his selections from the keyboard.

3.1 Configuration procedure

1. Make sure that the equipment is unpowered before connecting anything.
2. Connect the hardware according to the two figures below. Connect PROG pin 12 to ground. Use a PC as a DTE (Data Terminal Equipment).
3. Start a terminal program on PC (eg. Procomm, Telix). Set the following data parameters: 9600 bps, 8 data bits, no parity, 1 stop bit, which is always the default in configuration.
4. Switch the power for SATELNODE X8S on. The radio modem enters now the programming mode. A programming menu appears on the PC screen.
5. Modify the required settings. The detailed description is found on the next page.
6. Remember to unconnect the PROG pin, when the setup is ready.

Note: it is recommended to use a separate cable for the programming purpose.

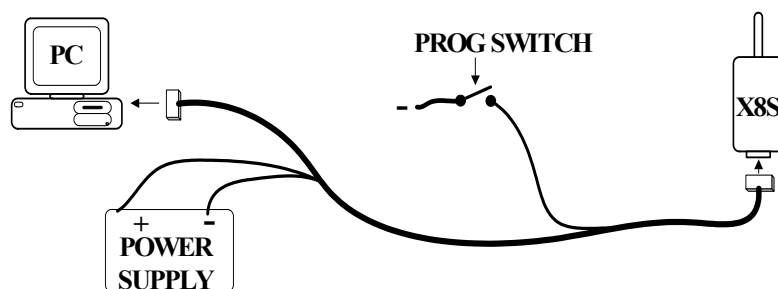

Figure 3.1 Configuration: installation

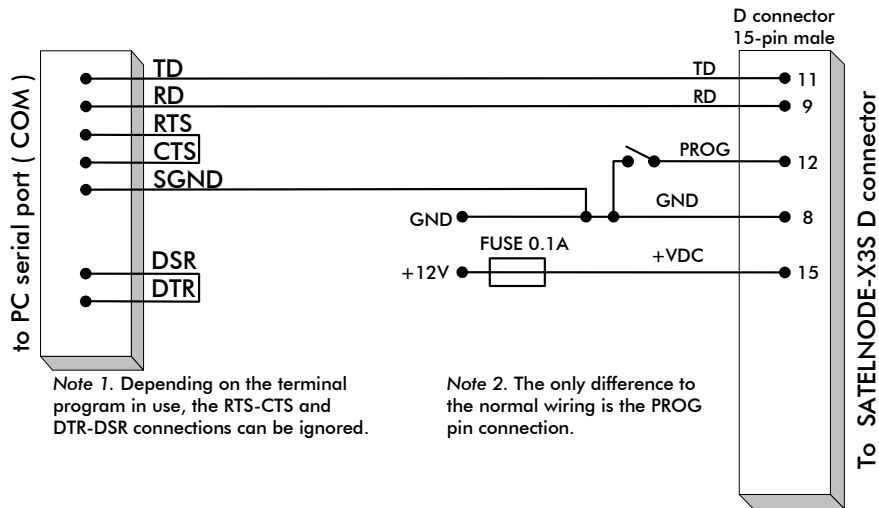

Figure 3.2 Configuration: wiring

3.2 Modifying setup: menu system

This paragraph explains how to change the setup. If you have followed the steps (1...4) of the configuration procedure, a programming menu appears on the PC screen. Below, the screen snapshot taken during a configuration session shows a typical main menu.

```

*** SATELNODE X8S Version 1.xx by SATEL OY +358-2-7777800 ***

F) Frequency          146.6750MHz (ChannelSpace=12.5kHz)
D) Data               9600bps
T) DuplicateTmo      OFF
P) Protocol          SIA (2003)
I) Id                035 (23hex) (Char # )
1) Output1           OFF
2) Output2           OFF
3) Output3           OFF
4) Output4           satelcode.00123.input1 -status
5) Output5           OFF
6) Output6           OFF
7) Output7           OFF
8) Output8           LinkMonitor
L) Link Monitoring
*) Tests
Q) Quit

Enter selection >

```

Figure 3.3 A screen snapshot taken from a pc during a configuration session.

The whole setup, the settings and the software version number, is listed in one menu. The alphanumericals on the left show the keyboard selections. A user types his selections from the keyboard. The paragraph 2.3 lists all the items in the programming menu.

Example 1. Changing the data speed. First, follow the steps on the previous pages (3.1 Configuration Procedure). When you have the setup menu on the screen, press key "D" to select the data settings. A submenu will be displayed, see the figure below.
When the required parameter has been succesfully changed you can escape back to the main menu by pressing "ESC" key at the prompt.

```
Data
----
Now: 9600bps      <---This line shows the current setting.

1) 1200bps
2) 2400bps      <---Available options are listed here.
3) 4800bps
4) 9600bps
5) 19200bps
6) 38400bps
7) 57600bps
8) 115200bps

Enter selection or ESC > 2 <---User typed "2" to get 2400 bps.
OK <---SATELNODE responds.The new value was stored succesfully.
```

Figure 3.4 A screen snapshot showing how to change the data speed.

Example 2. Changing the Duplicate removal timeout to 10 seconds. Select key "T" in the main menu, the submenu will be displayed:

```
DuplicateTmo
-----
Now: 005s

Enter new value (0-255) or ESC > 10 <---and "ENTER" keys.
OK <---SATELNODE responds with "OK" or an
    error message, if the value was invalid.

DuplicateTmo <---The submenu will be displayed again.
-----
Now: 010s <---Here you can see the new value.

Enter new value (0-255) or ESC > <---Pressing ESC will take you
    back to the main menu.
```

Figure 3.5 A screen snapshot showing how to change the Duplicate Removal Timeout.

When giving a new value, type the value first and then press the *ENTER* key.

Pressing *ESC* while entering a new value will cancel the operation, and the submenu will be displayed again, or the menu system will go to the previous level.

3.3 Modifying setup: parameters

The table below explains the settings found in the menu system, and their possible values.

Table 3.1. Setup parameters.

<i>Parameter name</i>	<i>Description</i>
Frequency	The radio frequency of the receiver.
Data	Defines the data speed of the RS-232 interface. Available values are 1200, 2400, 4800, 9600, 19200, 38400, 57600 or 115200 bits/s.
DuplicateTmo	Duplicate removal timeout. If a received message is identical to the previous one (ie. a duplicate), <u>and</u> comes within the timeout defined by DuplicateTmo, it is ignored. The value range is 0...255 seconds (0=no duplicate removal).
Protocol	Specifies the protocol on the RS-232 interface. A protocol covers message formats etc.
Id	Identifier of the SATELNODE X8S receiver.
Link Monitor Mode	There are two operational modes for link monitoring: Automatic – SATELNODE X8S adds any received transmitter to the list of monitored radio links. UserDefined – in this case user enters the identifiers of the SATELCODE transmitters manually in on the Monitored links submenu.
Link Monitor Time	The timeout (in minutes) for the link monitoring. In case any of the monitored transmitters fails to transmit in <i>Link Monitor time</i> minutes, an alarm indicating the failed links will be triggered.
Monitored links	The identifiers of the SATELCODE 8i transmitters whose radio connections are to be monitored. The max number of transmitters is 10...20 depending on the software version.
Output1 to Output8	Defines a) the event which activates the output, b) the resulting action of the output. See the next page.

3.4 Output definition

The output is configured by a character string which describes the triggering event. Characters can be typed in the programming menu. They are case insensitive.

Note: If the output is unused, enter the character string "OFF" to disable the output.

The syntax is: **TransmitterType.Identifier.Object -Switch1** where:

TransmitterType is the following according to the type of the transmitter.

SatelCode SatelCode transmitters which have a micro processor inside.

Identifier is the identifier (ie. the address) of the transmitter in decimal format.

Object defines the monitored target on the transmitter side.

Object options in case the TransmitterType is SatelCode:

InputX The input X of the transmitter, where X=1, 2,... or 8 .

*Input** Any input of the transmitter.

Battery The supply voltage of the transmitter.

nnnnn Sub-Identifier, where *nnnnn* is 1...64000.

-Switch1 defines the operational mode of the output. The possible options:

-Alarm The output is triggered, if a received alarm message contains the "alarm" information from the monitored object.
Once triggered, the output will remain triggered.
An acknowledgement is required to reset the output.

-Restoral The output is triggered, if a received alarm message contains the "restoral" information from the monitored object.
Once triggered, the output will remain triggered.
An acknowledgement is required to reset the output.

-Status The status of the monitored object is updated to the output, every time a message including the status info is received.

Note a special syntax case: The character string "**linkmonitor**" configures an output to be activated at the link failure alarm. In other words, if one or more of the monitored transmitters have been "silent" for more than the time defined by the parameter *Link Monitor Time*, the output configured as "linkmonitor" becomes activated until the alarm is acknowledged by the ACK pin.

<i>Table 3.2. Examples of the output configuration.</i>	
<i>Character string in the setup menu</i>	<i>Event which activates the output and the action</i>
satelcode.123.input1 -alarm	The input 1 of the Satelcode transmitter number 123 makes an alarm. The Satelnode X8S output is switched ON (conducts). An acknowledgement is required to reset it.
satelcode.12345.input2 -restoral	The input 2 of the Satelcode with the identifier number 12345 is restored (ie. returns back to normal state). The Satelnode X8S output is switched ON (conducts). An acknowledgement is required to reset the output.
satelcode.81.input1 -status	Satelnode X8S receives a message (alarm, restoral, diagnostics, wakeup), which includes the status ("alarm" or "restoral") of the Satelcode 81 input 1. The Satelnode X8S output will updated ON ("alarm") or OFF ("restoral") every time such a message comes.
satelcode.77.input* -alarm	Any input of Satelcode number 77 makes an alarm.
satelcode.12345.battery -alarm	Satelcode 12345 sends a low battery alarm.
satelcode.*.input1 -alarm ***Note1	The output is activated, if <u>any</u> Satelcode makes an alarm on its input 1.
satelcode.123.67 -alarm	Satelcode 123 sends an alarm with sub-identifier 67.
linkmonitor	The output indicates the link failure alarms. The list of the transmitters, whose radio connections are monitored, is defined in <i>Monitored links</i> sub-menu.
<i>Note 1: An identifier marked with a wildcard (" * ") denotes any identifier, ie. it is ignored.</i>	

4 RS232 PROTOCOLS

SATELNODE X8S provides two protocols in order to interface the receiver to user's monitoring equipment (usually a special monitoring software in a PC). The protocols use eight bits binary characters. The messages are written to the RD line (Received Data).

4.1 Satel SIA X8S protocol

The protocol is based on the SIA standard. The messages include the start byte, the stop byte, and alphanumerical characters (ie. readable!) between them. The length of the messages is always 19 bytes. Any event generates a separate message, in other words, a message describes one event. The major differences between Satel SIA X8S and the older Satel SIA X3S protocol are that the former includes an RSSI (Received Signal Strength Indicator) and a checksum field, the latter does not.

Messages: The total size of any message is 19 bytes. LF (LineFeed) starts a message, CR (Carriage Return) terminates a message.

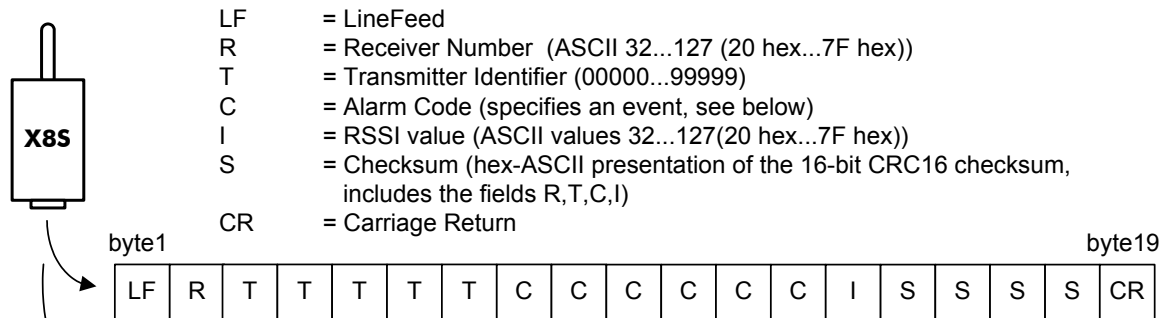

Heartbeat: Unless SatelNode-X3S has not written anything on the RS-232 line during the last <To_Be_Defined> seconds, it writes a heartbeat ('receiver alive') on the RS-232 line. A heartbeat is a single byte 05hex (ENQ).

LineFeed (0A hex) starts a new message.

Receiver Number identifies the SatelNode receiver. The Receiver number can be utilized on grouping or routing messages in large systems which use several receivers.

Transmitter Identifier identifies the sender of the message.

The Alarm Code field in the message describes an event. The length of the Alarm Code is six bytes. The bytes may have number values (0...9), letters (A...Z), or NULL (00 hex). Any unused character slot is fed with a NULL character (00hex) The list on the next page describes the alarm codes.

RSSI indicates the signal strength of a received message i.e. the quality of a radio link.

Checksum is used for error detection purposes. The calculation includes the fields R, T, C, I , starting from R, byte by byte. See the paragraph *Checksum*.

Carriage Return (0D hex) terminates a message.

Satel SIA X8S Protocol: Satelcode Transmitter related Alarm Codes

Alarm Code Description

<i>Wabcd</i>	WakeUp (Transmitter sends this once when power is connected), where <i>abcd</i> present the status of odd numbered inputs: <i>a</i> =status of Input1 (1=active, 0=inactive) <i>b</i> =status of Input3 (3=active, 0=inactive) <i>c</i> =status of Input5 (5=active, 0=inactive) <i>d</i> =status of Input7 (7=active, 0=inactive)
<i>Cabcd</i>	Diagnostic (ie. transmitter alive), where <i>abcd</i> present the status of odd numbered inputs. <i>a</i> =status of Input1 (1=active, 0=inactive) <i>b</i> =status of Input3 (3=active, 0=inactive) <i>c</i> =status of Input5 (5=active, 0=inactive) <i>d</i> =status of Input7 (7=active, 0=inactive) Note on naming: "Diagnostic message" replaces "Poll message", which was used in the same context in earlier product documentation.
I1	Input1 Alarm
I2	Input2 Alarm
I3	Input3 Alarm
I4	Input4 Alarm
I5	Input5 Alarm
I6	Input6 Alarm
I7	Input7 Alarm
I8	Input8 Alarm
R1	Input1 Restoral
R2	Input2 Restoral
R3	Input3 Restoral
R4	Input4 Restoral
R5	Input5 Restoral
R6	Input6 Restoral
R7	Input7 Restoral
R8	Input8 Restoral
BP	ByPass Alarm (ByPass input activated)
BR	ByPass Restoral (ByPass input de-activated)
S<InputId>	Input Alarm with a special InputId (ie. a sub-identifier)
E<InputId>	Input Restoral with a special InputId (ie. a sub-identifier)

LBxxxx	LowBattery Alarm, where xxxx is optional, describing the level of supply voltage.
LRxxxx	Battery Restoral, where xxxx is optional, describing the voltage level.
Txxxx	Test message, where xxxxx defines test data.
M	New radio connection failure i.e. the transmitter in the list of the monitored links is found "not alive".
P	Repetitive radio connection failure. If the monitored radio link remains silent, this message will be created at time intervals defined by the <i>Link Monitor Time</i> parameter.
Y	Radio link connection restored.
U11	Unidentified message (=message not defined in the receiver)

Satel SIA X8S Protocol: ED code related Alarm Codes

Note: The reception of ED transmitters is supported only by the special "ED" marked software versions of SATELNODE X8S.

Note: the alarm codes listed below work only with older versions of SATELCODE transmitters (the versions without a micro processor) which are controlled by the special ASC-1 adapters. If you are not familiar with the ED codes and the ASC-1 adapters, ignore this paragraph!

Alarm Code Description

SAabcd	Alarm where <i>abcd</i> present the status of the four inputs: a=status of Input4 (4=active, 0=inactive) b=status of Input3 (3=active, 0=inactive) c=status of Input2 (2=active, 0=inactive) d=status of Input1 (1=active, 0=inactive)
SPabcd	Diagnostic (ie. transmitter alive), where <i>abcd</i> present the status of the four inputs. a=status of Input4 (4=active, 0=inactive) b=status of Input3 (3=active, 0=inactive) c=status of battery (8=battery ok, 9=low battery) d=status of Input1 (1=active, 0=inactive)

Note on naming: "Diagnostic message" replaces "Poll message", which was used in the same context in some earlier product documentation.

Checksum of SATEL SIA X8S protocol

The checksum to be used is a 16 bit CRC (Cyclic Redundancy Check) checksum. Bytes 2 to 14 of the message frame i.e. the fields R, T, C and I are included in the checksum.

The contents of the Checksum field of the actual message (SSSS) can be derived by converting the 16 bit binary CRC checksum to four hex-ascii characters.

C - function for calculating crc checksum:

The source code listing written in C language below can be applied to calculate the binary value of CRC:

```
unsigned short CRC_16 (unsigned char length, unsigned char *data)
{
    unsigned short crc_table[16] =
    {
        0x0000, 0x1081, 0x2102, 0x3183, 0x4204, 0x5285, 0x6306, 0x7387,
        0x8408, 0x9489, 0xA50A, 0xB58B, 0xC60C, 0xD68D, 0xE70E, 0xF78F
    };

    unsigned short crc = 0x0000;
    unsigned char tmp, index, i;

    for (i = 0; i < length; i++)
    {
        tmp = data[i];
        index = ((crc ^ tmp) & 0x000F);
        crc = ((crc >> 4) & 0x0FFF) ^ crc_table[index];
        tmp >>= 4;
        index = ((crc ^ tmp) & 0x000F);
        crc = ((crc >> 4) & 0x0FFF) ^ crc_table[index];
    }

    return (~crc);
}
```

Example: <LF>912345R1<NULL><NULL><NULL><NULL>A19A3<CR> is a valid message. Here: <LF> is the start of the message, Receiver Number is '9' (0x39 in hexadecimal), Transmitter Identifier is 12345, the Alarm Code is R1 (Restoral of Input 1) – the rest of the Alarm Code slots are NULL characters. The checksum is calculated from binary values of the characters starting from "9" and the last character to be included in the calculation is "A".

4.2 Satel SIA X3S protocol

The protocol is based on the SIA standard. The messages include the start byte, the stop byte, and alphanumerical characters (ie. readable!) between them. The length of the messages is always 19 bytes. Any event generates a separate message, in other words, a message describes one event. The difference between Satel SIA X8S and the older Satel X3S protocol is that the former includes an RSSI (Received Signal Strength Indicator) and a checksum field, the latter does not.

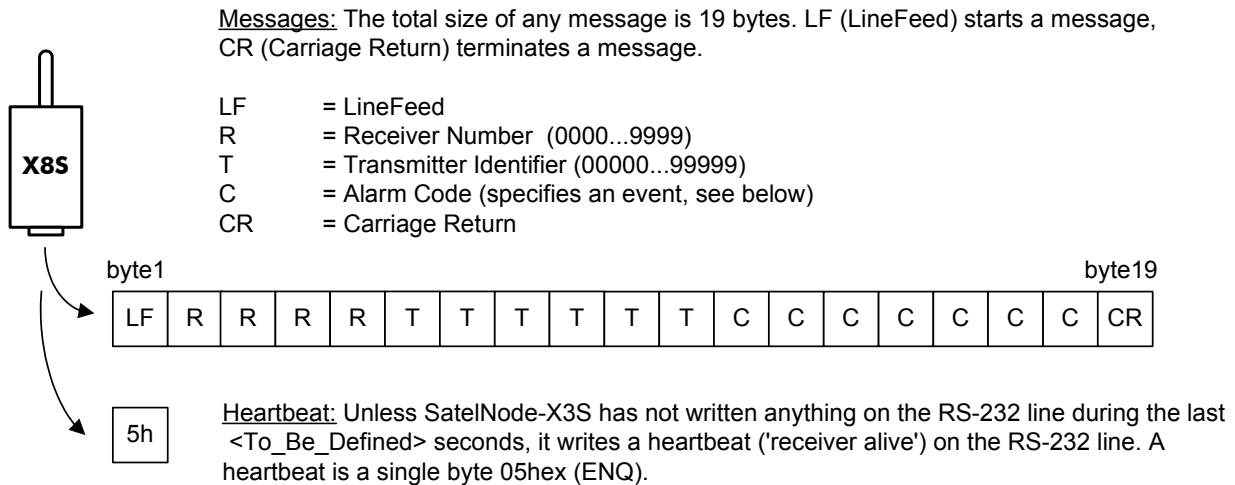

LineFeed (0A hex) starts a new message.

Receiver Number identifies the SatelNode receiver. The Receiver number can be utilized on grouping or routing messages in large systems which use several receivers.

Transmitter Identifier identifies the sender of the message.

The Alarm Code field in the message describes an event. The length of the Alarm Code is seven bytes. Any unused character slot is fed with a NULL character (00hex). Both the first byte and the second byte are always letters (A...Z), the rest of the bytes may have number values (0...9) or NULL (00 hex). The list on the next page describes all the possible alarm codes.

Carriage Return (0D hex) terminates a message.

Satel SIA X3S Protocol: Satelcode Transmitter related Alarm Codes

<u>Alarm Code</u>	<u>Description</u>
SWabcd	WakeUp (Transmitter sends this once when power is connected), where <i>abcd</i> present the status of odd numbered inputs: a=status of Input1 (1=active, 0=inactive) b=status of Input3 (3=active, 0=inactive) c=status of Input5 (5=active, 0=inactive) d=status of Input7 (7=active, 0=inactive)
SCabcd	Diagnostic (ie. transmitter alive), where <i>abcd</i> present the status of odd numbered inputs. a=status of Input1 (1=active, 0=inactive) b=status of Input3 (3=active, 0=inactive) c=status of Input5 (5=active, 0=inactive) d=status of Input7 (7=active, 0=inactive) Note on naming: "Diagnostic message" replaces "Poll message", which was used in the same context in earlier product documentation.
SI1	Input1 Alarm
SI2	Input2 Alarm
SI3	Input3 Alarm
SI4	Input4 Alarm
SI5	Input5 Alarm
SI6	Input6 Alarm
SI7	Input7 Alarm
SI8	Input8 Alarm
SR1	Input1 Restoral
SR2	Input2 Restoral
SR3	Input3 Restoral
SR4	Input4 Restoral
SR5	Input5 Restoral
SR6	Input6 Restoral
SR7	Input7 Restoral
SR8	Input8 Restoral
SL0	Battery Restoral
SL1	LowBattery Alarm
SS<InputId>	Input Alarm with special InputId (=SubId)
SE<InputId>	Input Restoral with special InputId (=SubId)
SU11	Unidentified message (=message not defined in the receiver)

Satel SIA X3S Protocol: ED code related Alarm Codes

Note: the alarm codes listed below work only with older versions of SATELCODE transmitters (the versions without a micro processor) which are controlled by the special ASC-1 adapters. If you are not familiar with the ED codes and the ASC-1 adapters, ignore this paragraph!

Alarm Code Description

SAabcd	Alarm where <i>abcd</i> present the status of the four inputs: <i>a</i> =status of Input4 (4=active, 0=inactive) <i>b</i> =status of Input3 (3=active, 0=inactive) <i>c</i> =status of Input2 (2=active, 0=inactive) <i>d</i> =status of Input1 (1=active, 0=inactive)
SPabcd	Diagnostic (ie. transmitter alive), where <i>abcd</i> present the status of the four inputs. <i>a</i> =status of Input4 (4=active, 0=inactive) <i>b</i> =status of Input3 (3=active, 0=inactive) <i>c</i> =status of battery (8=battery ok, 9=low battery) <i>d</i> =status of Input1 (1=active, 0=inactive)

Note on naming: "Diagnostic message" replaces "Poll message", which was used in the same context in earlier product documentation.

5 SATELNODE X8S SYSTEM DESIGN

A typical system layout is illustrated below. The alarm network consists of one monitor station and several substations. The SATELNODE X8S receiver is attached to the monitor station computer. The receiver outputs the received messages to RS-232 interface. In small systems (1...8 transmitters) the received alarms are often wanted as switch contacts. In that case relay outputs of SATELNODE X8S can be utilized. It has 8 relays, which are activated on the user selected messages or events.

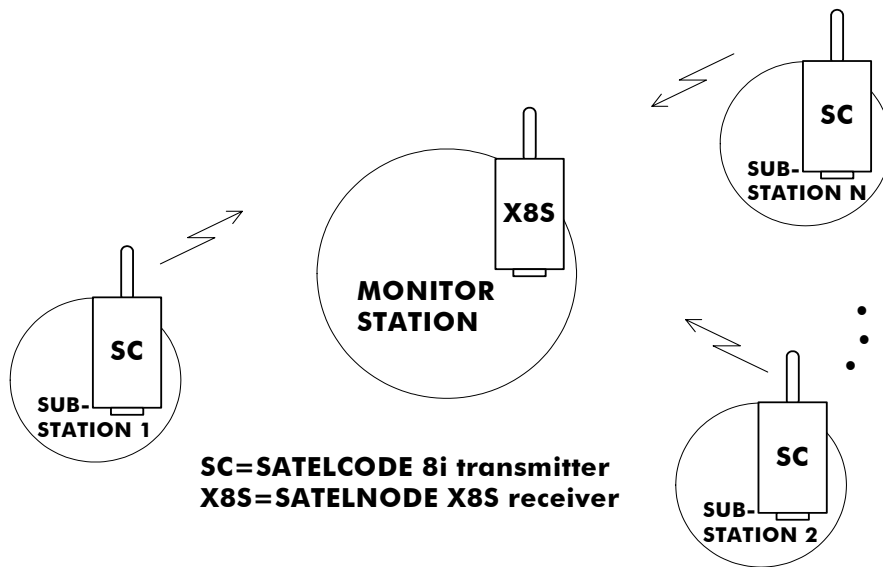

Figure 5.1 A typical system layout with a monitor station and 1...N substations.

The monitor station a) keeps track on the status of the system; alarms, failed transmitters etc., b) decodes received messages, and c) handles other tasks like operator interface or alarm dispatching. The monitor station software must be implemented by the system integrator party according to the system specific needs. Consult the manufacturer for more information, if support is needed.

Substations locate in the monitored premises. There are usually opening or closing switch contacts, which SATELCODE transmitters are connected to. When a switch changes its state, SATELCODE sends the new status information. The distance between a substation and a monitor station may not exceed the range of radio communication (typically 3-15 km). The range depends very much on the antenna arrangement and the environment. The range may be extended by using repeater stations. A repeater forwards messages between substations and the monitor station. Do not hesitate to contact SATEL, if you need more information on planning a large system.

The quality or the range of a radio connection depends very much on:

- transmitter power
- receiver sensitivity
- tolerance of the radio modulating signal against spurious radiations
- antenna amplification both at the transmitter and the receiver
- antenna cable attenuation
- antenna height
- natural obstacles
- radio interferences

The transmitter power of SATELCODE is up to 4W and sensitivity of the SATELNODE receivers is better than -116dBm which means that links ranging from 5 to 30km can be achieved. Distances may be considerably shorter if there are metallic walls or material inhibiting the radio wave propagation.

Problems caused by natural obstacles with long distance links can often be solved by raising the height of antennas. Also, amplifying antennas may result a ten fold increase in distances. Frequent topographical variations over long distances may require, that at least one of the antennas need to be raised to the height of 10 - 20 m. If the base station antenna cable is longer than 10 m, it is necessary to use a low loss cable (≤ 0.7 dB /10m) in order not to waste the antenna amplification.

Problematic links can also be solved by adding a repeater station. In systems with many base stations or substations, RSSI-signal measurements should be carried out in order to build the links properly. A sufficient safety margin can be obtained by testing communications using an extra 6 dB rejection at the antenna connection and with slightly less effective antennas than those to be used in the final system. Figure 6.2 illustrates an example of an antenna installation in a system which has one base station and several substations.

Ground, ground contours and buildings cause attenuation (loss of energy through absorption) and reflections of radio waves. Buildings reflect radio waves and therefore the affects of attenuation are not as acute when transmission is over a short distance.

However, the reflected waves will suffer a loss in power once they travel over a certain distance, this means that they combine with the direct radio waves and interact to either weaken or strenghten the signal respectively. In reality, this fading can be even 40 dB.

The signal strength may vary heavily by changing the location of the antenna just a few decimeters in such conditions.

SATELNODE X8S copes with the normal levels of interference. However, pay attention to the possible sources of interference such as:

- mobile or local phone network base stations, television transmitters
- radio links
- other radio modem networks
- PC equipment (about a radius of 5 m from the antenna)

6 INSTALLATION

6.1 Mounting

Mount SATELNODE X8S properly using the holes in the back plate. Protect it from an environmental hazard such as water seepage. Do not install SATELNODE X8S in a strongly vibrating foundation. Keep the temperature in the range -25 °C...+55 °C .

6.2 Cable connections

The figure below illustrates the wiring of SATELNODE X8S to a PC. SATELNODE X8S writes its RS-232 messages on the RD (Received Data) line. The TD line (Transmitted Data) is used only during the configuration, when a user enters his selections in the programming menu.

Tighten the screws of D15 connector properly.

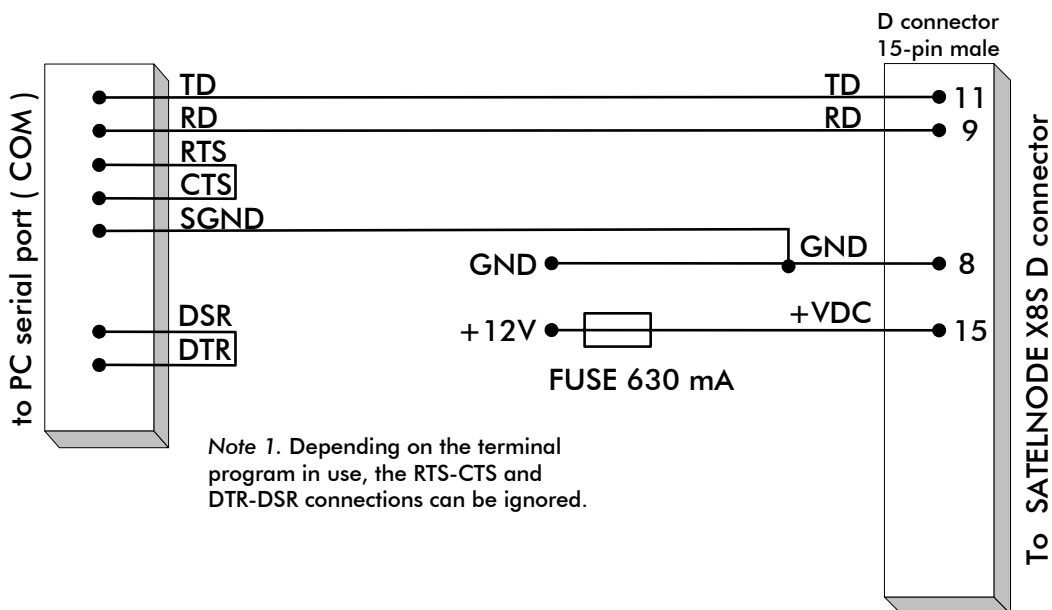

Figure 6.1. The interface between SATELNODE X8S and a terminal.

6.3 Antenna installation

Connect the antenna to the TNC connector on top of SATELNODE X8S. It is possible to use an antenna cable in order to get the antenna placed optimally. A good quality 50 ohm RF cable can be used (e.g. RG58), if the length is shorter than 5 m. In case a longer cable is required, use a low loss RF cable.

As a standard cable SATEL supplies 50 ohm RG58 cable in lengths of 1 m (CRF-1) and 5 m (CRF-5). Choose your antenna cable according the following recommendations:

<i>Length</i>	<i>Type</i>	<i>Attenuation</i>
< 5 m	RG58	2.0 dB/10 m/200 MHz
5... 20 m	RG213	0.9 dB/10 m/200 MHz
> 20 m	RFX 1/2"-50	0.3 dB/10 m/200 MHz
> 20 m	AirCom+	0.5 dB/10 m/200 MHz *)

*) AirCom+ cable is partly air insulated, thus an absolutely air tight connection between the cable and the connector is required.

Performance of your radio link depends very much on antenna arrangement. The antenna should always have as much open space around it as possible. Metallic objects should locate at least 1m away from the antenna. The metal-free zone around should be at least >5 m in case of big antennas and >10 m around a repeater antenna combination. The best place for the antenna is in general is at the highest point of the building or in a radio mast. If a mast is used, the antenna can be installed using a side-installation up to 2 ...3 m away from the mast itself.

There should always be a gold plated connector in antenna cables and terminal adaptors. Since connectors of poor quality oxidate and increase the attenuation in the course of time, appropriate connectors and proper tools must always be used in mounting. One should also check that both the antenna and possible fitting elements resist weather and environmental contamination well.

When ordering antennas, please note that the antennas have been tuned to a certain frequency range. Simple antennas and those made of stacked yagis are relatively wide band. The frequency range of the antenna becomes narrower the more elements there are in a yagi.

Keeping in mind the testing and service of the system, it is generally useful to use rather a long antenna cable in order to avoid the installation of radio modems near the antenna into a place possibly difficult to access.

In great distances when the antennas are in line of sight positions a 6 dB power marginal is adequate. Since the connection is built on the reflection and/or the knife-edge diffraction the path loss can vary even 20 dB depending on the weather conditions. In this case a short test can give a too positive result of the quality of the connection. Thus the height of the antennas and topographical obstacles must be surveyed with great care.

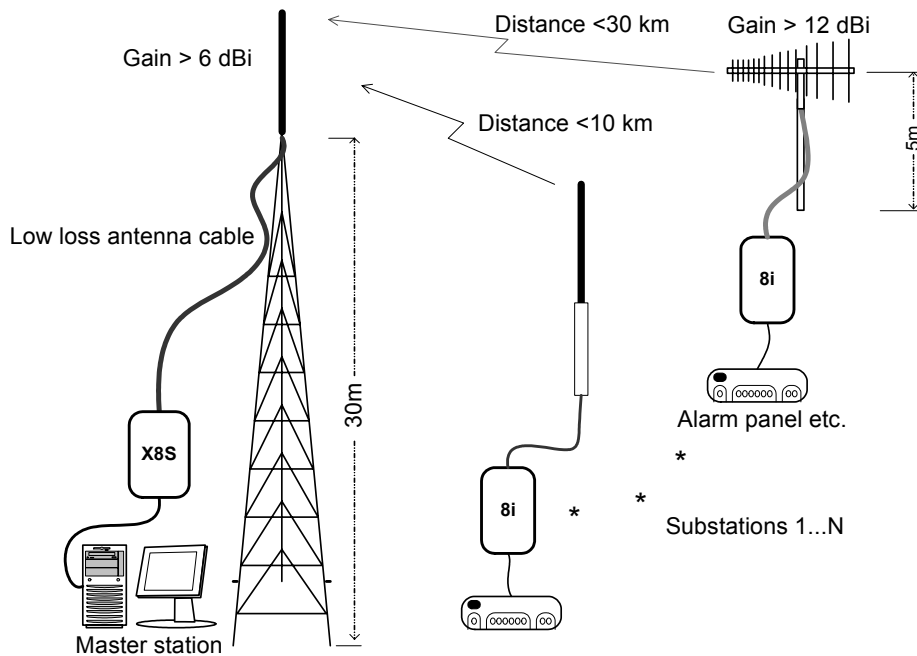

Figure 6.2 An example of antenna installations: long distances can be reached by using amplifying antennas and by installing them in high locations.

Vertically polarized systems (antenna elements are in vertical position) are often used in radio systems. In a system between a base station and sub-stations the vertical polarization is generally recommendable. The antenna of the radio modem can not be mounted on the same level with the other sub-station antennas in the same building. The best way to distinguish from the other antennas situated in neighbourhood is by mounting the antennas as far as possible from each other on the altitude level. The best result is generally obtained when all the antennas are in the same mast. With an extra ground plane between the antennas more distinction can be obtained between the antennas in the mast.

Horizontal polarization can be used in data transmission between two points. With the polarization attenuation more distinction is obtained in the vertical polarization interference. The influence of the directional patterns of the antennas must, however, be taken into consideration. If a distinction to another interfering antenna is wanted with the horizontal polarized antennas there must be a good attenuation of the back lobe. In addition to this, the interfering radiator should be situated behind the antenna.

When the system does not demand the use of an omnidirectional antenna it is recommendable to use directional antennas e.g. two-element yagis in firm external installations. As the antenna amplification increases the setting of the direction of the antenna demands for a greater care.

The base stations in high places should be supplied with 4...6 degree band-pass filters. Please note that the higher the antenna the larger the broadcast area. The disadvantages with a too high antenna installation at the base station are that interferences from a larger area affect the base station.

7 TECHNICAL SPECIFICATIONS OF SATELNODE X8S

SATELNODE X8S fulfils the requirements of the ETS 300 113 standard.

Frequency Range	140 ... 170 MHz
Number of Channels	160 (12,5kHz) 80 (25kHz)
Frequency Stability	± 4 ppm
Sensitivity	better than -116 dBm (95% of the messages received correctly)
Operating voltage	+ 9...+12 V _{DC}
Current consumption max.	max. 400 mA
Temperature range	-25°C ...+55°C
Antenna connector	TNC, 50 ohms
Interface Connector	D connector, 15-pin female
Programming Interface	RS-232
RS-232 Data format	1200, 2400, 4800, 9600,19200, 38400, 57600,115200 bps 8 data bits / No parity
Control outputs	8 relay outputs (max. load 1A totally)
Size H x W x D	130 x 65 x 26 mm
Weight	240 g

8 OTHER RELATED PRODUCTS BY SATEL

8.1 SATELCODE 8i alarm transmitter

SATELCODE 8i is a one-way radio alarm transmitter. It is an ideal product for a wide range of wireless alarm transfer applications. SATELCODE 8i operates on the VHF band. The power level of the transmitter is max 4W. Together with the sensitive SATELNODE X8S receiver, SATELCODE 8i easily provides radio connections over 15 kilometers. SATELCODE 8i consists of the transmitter, the synthesizer and the processor logic, housed in a compact, strong aluminium casing.

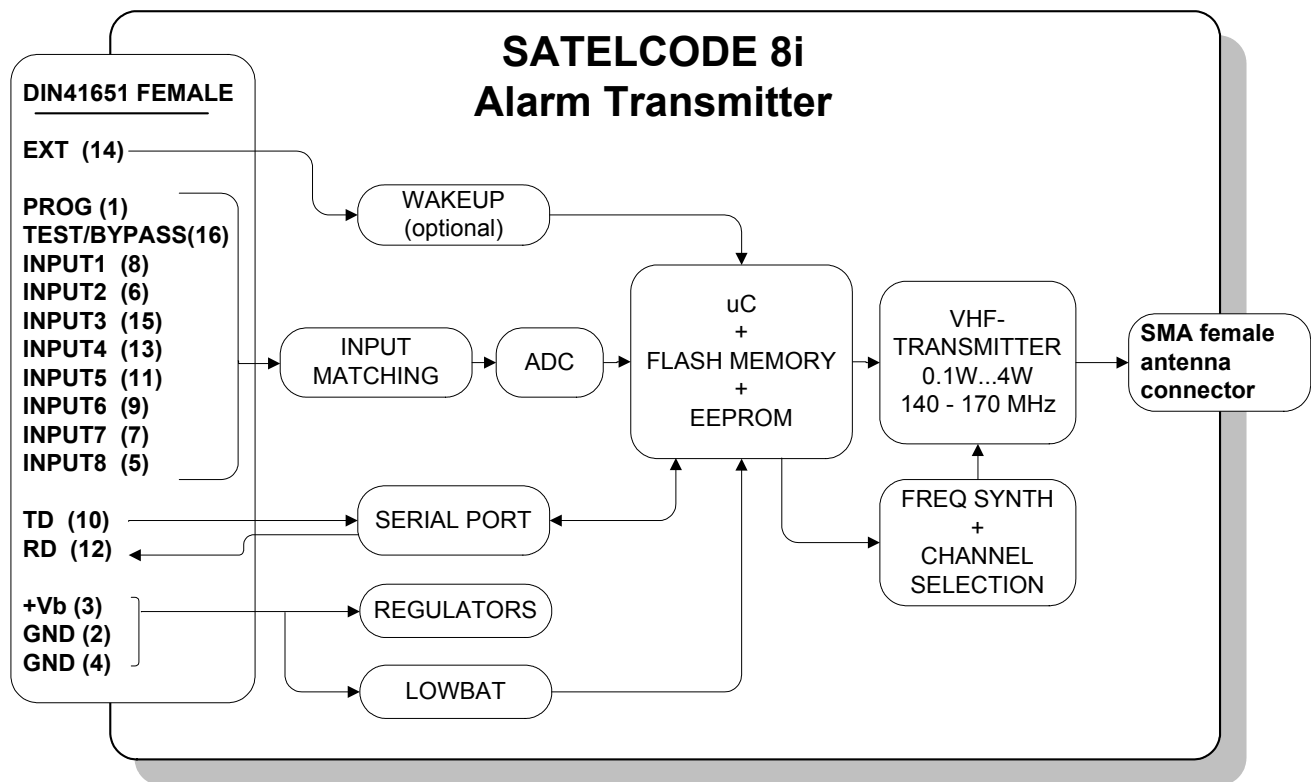

Figure A. SATELCODE 8i Block Diagram

The user configurable alarm inputs provide the flexibility to connect SATELCODE 8i to a wide variety of equipment in alarm networks. Several built-in functions like the diagnostic, the bypass or the test function, as well as the possibility to set network related parameters make SATELCODE 8i the product with many applications in wireless alarm communication.

9 CHECK LIST

1. Consider the exact location of the equipment for optimum results.
 - Place the antenna in a free space as far as possible from any source of interference.
 - Do not place the radio modem on a strongly vibrating surface.
 - Do not place the radio modem in high humidity.
2. Ensure the capacity and stability of the power supply. Is the voltage correct (+9...14 VDC)?
3. Check that the antenna is installed according to given instructions.
4. Check that the RS-232 lines of are connected firmly. Check the order the TD and RD lines.
5. The settings of the radio modem must match the application. Is the data speed and the protocol compatible with the terminal equipment (PC). Also, all the radio modems in your system should be configured with compatible settings e.g. same radio frequency, correct addresses etc. Check the settings.
6. After checking all above listed, if you still have problems, contact the manufacturer. Before calling, write down the useful info:
 - serial number and the software version of the radio modem
 - the setup of the radio modem (eg. printscreen of the programming menu)
 - antenna: type, cables, placing
 - power supply: type, cabling
 - wiring diagram of the radio modem in your system
 - when and how did the problem appear