

USER MANUAL

SATEL MINI-LINK

I/O-converter

TABLE OF CONTENTS

TABLE OF CONTENTS	2
IMPORTANT NOTICE	3
PRODUCT CONFORMITY	4
WARRANTY AND SAFETY INSTRUCTIONS	5
1 GENERAL.....	6
1.1 SATEL MINI-LINK PULSE COUNTER AND I/O -CONVERTER.....	6
2 SPECIFICATIONS.....	7
3 FUNCTIONS.....	8
SCREW CONNECTOR FUNCTIONS.....	8
3.1 SUPPLY VOLTAGE, 9 – 30 VDC	8
3.2 ALARM OUTPUT, AL OUT.....	8
3.3 + OUT.....	8
3.4 DIGITAL INPUTS, I1, I2, AND OUTPUTS O1, O2	8
3.5 PULSE INPUT.....	8
3.6 INDICATORS.....	8
3.7 DIP-SWITCHES	9
3.7.1 DIP -switches, 8 pcs	9
3.7.2 Address selection table.....	9
3.7.3 Channel selection table.....	9
4 OPERATION	11
4.1 POINT- TO-POINT.....	11
4.1.1 Updating Digital messages.....	11
4.1.2 Start of the Point-to-Point operation	11
4.2 POINT-TO-MULTIPOINT	11
4.2.1 Start of the Multipoint operation	11
5 FACTORY SETTINGS.....	12
6 CONNECTION EXAMPLES.....	13
7 ACCESSORIES	14

IMPORTANT NOTICE

All rights to this manual are owned solely by SATEL OY (later called also SATEL). All rights reserved. The copying of this manual without the written permission from the owner of the rights by printing, copying, recording or by any other means or the full or partial translation of the manual to any other language including all programming languages using any electrical, mechanical, magnetic, optical, manual or other methods or devices is forbidden.

SATEL reserves the right to change the technical specifications or functions of its products or to discontinue the manufacture of any of its products or to discontinue the support of any of its products without any written announcement and urges its customers to ensure, that the information at their disposal is valid.

SATEL software and programs are delivered "as is". The manufacturer does not grant any kind of warranty including guarantees on saleability and guarantees pertaining to applicability to a certain application. Under no circumstances is the manufacturer or the developer of a program responsible for any possible damages caused by the use of a program. The names of the programs as well as all copyrights relating to the programs are the sole property of SATEL. Any transfer, licensing to a third party, leasing, renting, transportation, copying, editing, translating, modifying into another programming language or reverse engineering for any intent is forbidden without the written consent of SATEL.

SATEL PRODUCTS HAVE NOT BEEN DESIGNED, INTENDED NOR INSPECTED TO BE USED IN ANY LIFE SUPPORT RELATED DEVICE OR SYSTEM RELATED FUNCTION NOR AS A PART OF ANY OTHER CRITICAL SYSTEM AND ARE GRANTED NO FUNCTIONAL WARRANTY IF THEY ARE USED IN ANY OF THE APPLICATIONS MENTIONED.

PRODUCT CONFORMITY

SATEL MINI-LINK

Hereby, SATEL Oy declares that SATEL MINI-LINK converters are in compliance with the essential requirements and other relevant provisions of Directive 89/336/EEC. Therefore the equipment is labelled with the following CE-marking.

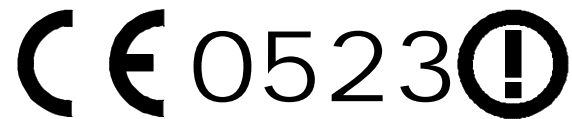



DECLARATION of CONFORMITY

In Accordance with
89/336/EEC Directive

of the European Council of 3rd May 1989 on the approximation of the laws of the Member States relating of electromagnetic compatibility

Doc No: SATEL-DC-EMC-002

Manufacturer: **SATEL Oy**

Address: P.O.Box 142, (Merilinjankatu 17)
24101 Salo
FINLAND

Product: **SATEL I-LINK 100 / 200 / 300** I/O Converters
SATEL C-LINK Pulse Counter
SATEL MINI-LINK I/O Converter and Pulse Counter

Application: External products for SATELLINE Radio Modems

We, the manufacturer of the above mentioned products, hereby declare that these products conform to the requirements of the European Council directive 89/336/EEC. This Declaration of Conformity is based on that the manufacturer has tested the Products according to the following standards: EN 50140 (RF Immunity), EN 55022 / CISPR 22 (RF Emission), EN 61000-4-2 (ESD) and EN 61000-4-4 (EFT/Burst).

Salo on the 24th of October, 2005.

SATEL OY
Pekka Aho
Managing Director



SATEL OY P.O.Box 142, FIN-24101 SALO, FINLAND
Puhelin Merilinjankatu 17, FIN-24100 SALO, FINLAND
Faksi +358 2 777 7800; Faxi +358 2 777 7810, Email info@satel.fi
www.satel.fi

WARRANTY AND SAFETY INSTRUCTIONS

Read these safety instructions carefully before using the product:

Warranty will be void, if the product is used in any way, which is in contradiction with the instructions given in this manual, or if the housing of the radio modem has been opened or tampered with.

The radio modem is to be used only on frequencies allocated by local authorities and without exceeding the given maximum allowed output power ratings. SATEL is not responsible, if any products manufactured by it are used in unlawful ways.

The devices mentioned in this manual are to be used only according to the instructions described in this manual. Faultless and safe operation of the devices can be guaranteed only if the transport, storage, operation and handling of the devices are appropriate. This also applies to the maintenance of the products.

To prevent damage both the radio modem and any terminal devices must always be switched OFF before connecting or disconnecting the serial connection cable. It should be ascertained that different devices used have the same ground potential. Before connecting any power cables the output voltage of the power supply should be checked.

Salo, Finland 2005

1 GENERAL

1.1 SATEL MINI-LINK Pulse Counter and I/O -converter

The SATEL MINI-LINK is a Point-to-Point or Point-to-Multipoint transparent I/O-converter with a pulse counter input. The device works together with SATELLINE-1870 radio modems. In Point-to-Point transmission the digital status information can be sent through the radio modem to output in the other end. In Point-to-Multipoint mode it is also possible to read information from pulse transponders. Point-to-Multipoint transmission is possible adopting software suitable for the SATEL MINI-LINK.



Screw connectors from left to right

1 = minus	MINI-LINK ground
3 = 9-30 VDC / - +	Supply Voltage
4 = + OUT	+ out for other devices
5 = AL OUT 	Alarm output
6, 7 = I1, I2	Digital inputs
8 = 10 kHz	Pulse Input
9 -12 = O1, O2	Digital outputs from internal relay contacts

Indicators

ON	Power ON/OFF
ALARM	Failure in transmission/device
I1, I2	Digital inputs
O1, O2	Digital outputs
P1	Pulse counter input

DIP-Switches 8 pcs

1 PRTCL, Protocol	0=P-to-P, 1=Point-to-Multipoint
2, 3, 4, 5 / P-to-P	ADDRESS. Max 15.
2, 3, 4, 5 / P-to-MP	CHANNEL. 10 channels.
6	Transmission cycle
	0= once/ second (by European standard)
	1= 3 times/second
7 DE	Alarm Delay. 1=ON. 0= OFF
8 SM	Safe Mode. 1=ON. 0= OFF

2 SPECIFICATIONS

FEATURE	min-max	typical	note
Supply Voltage	9...30 Vdc		Supply Voltage to MINI-LINK regulated by the radio modem (5.3 Vdc)
Power consumption	0.03...0.1 VA	40 mA @ 12Vdc	
Serial Interface	RS-232 ± 15 Vdc	± 6 Vdc	active RS-232
Response time	< 250 ms	< 300 ms	@ 9600 bps
Operational temperature	-25...+55 °C		
Transfer rate	9600 bps		
PULSE COUNTER			
Inputs, 1 pc	max. 10 kHz		
Minimum pulse width	5 μs		
DIGITAL SIGNALS			
Inputs, 2 pcs	0 – 35 Vdc	0 – 30 Vdc	resistive 4-5 kΩ,
Outputs, 2 pcs	0 – 30 V DC/AC/1 A		relay contacts (normal= open)
INDICATORS			
Indicators	Power ON/OFF, Digital IN/OUT, Alarm, Pulse IN.		
OTHER OUTPUTS			
Alarm Output	9 – 35 Vdc / 30 mA		Alarm= + supply voltage drive current 30 mA.
GENERAL			
Housing	Metal plate, painted		
Connectors	16 pins for SATELLINE-1870 12 pins for other connections		
Size L x W x H	123 x 85 x 30 mm		
Weight	80 g		
Mounting	Wall plate		
IP	IP-20		
Modem compatibility	SATELLINE-1870		

3 FUNCTIONS

Screw connector functions

3.1 Supply Voltage, 9 – 30 Vdc

- The minus contacts are in parallel. One is for the MINI-LINK and another can be used for external devices and connections. Plus (+) is for supply voltage.

3.2 Alarm output, AL OUT

- The AL OUT is activated, when three transmission fails has occurred one after another. When activated the AL OUT goes to +VDC. Driving current is max. 30 mA.

3.3 + OUT

- + OUT is internally connected to + VDC through an automatic fuse. The supply voltage for other devices.
- Connections can be taken from the +OUT.

3.4 Digital Inputs, I1, I2, and Outputs O1, O2

- Inputs,
 - 2 pcs. Activated with + VDC. A transmission is made always when there is a change in the input (P-to-P). Minimum Voltage for "1"-state triggering is 7 Vdc.
- Outputs,
 - 2 pcs. Open relay contacts. Max. rating 9 – 30 VDC / AC / 1 A load.

3.5 Pulse Input

Can be used only in Point-to-Multipoint mode.

- For fast pulses. Maximum frequency is 10 kHz.

3.6 Indicators

- ON
 - Power ON/ OFF. Illuminated when +VCD is connected. Blinking, if the device is not working.
- O1...O2, PO... PO1
 - Showing the status of the input and output. Illuminated when the consequently pin is activated.
- ALARM
 - Illuminated, if a fail in transmission has occurred. If the MINI-LINK has not received confirmation to the sent message, it will repeat the transmission. Three fails in turn switches the AL OUT and the alarm LED ON.
- I1...I2, PI1...PI2
 - Showing the status of the Input. Illuminated when the consequently pin is activated.

3.7 DIP-Switches

3.7.1 DIP -switches, 8 pcs

1 MP, Protocol-switch

1 = M, for Point-to-Multipoint (Master-Slave) -operation

0 = P, for Point-to-Point -operation

Point-to-Multipoint operation mode

2, 3, 4, 5, ADDRESS

Used in Point-to-Multipoint -operation to set channel for the sub-station.

Maximum number of addresses is 15.

3.7.2 Address selection table

DIP 2 3 4 5

0 0 0 0= reserved for the Main Station

0 0 1 0= address 2

0 1 0 0= address 4

0 1 1 0= address 6

1 0 0 0= address 8

1 0 1 0= address 10

1 1 0 0= address 12

1 1 1 0= address 14

DIP 2 3 4 5

0 0 0 1= address 1

0 0 1 1= address 3

0 1 0 1= address 5

0 1 1 1= address 7

1 0 0 1= address 9

1 0 1 1= address 11

1 1 0 1= address 13

1 1 1 1= address 15

Point-to-Point operation mode

2, 3, 4, 5 CHANNEL

Used in Point-to-Point-operation to select / change the operational channel.

When the power is turned ON, the MINI-LINK reads the channel information from the DIP - switches. Default mode setting is 0-0-0-0, 1=up / 0=down.

The channel can be changed by turning first the power OFF and then by setting the DIP - switches (channel selector) to selected channel position for example 1-0-0-0.

3.7.3 Channel selection table

DIP 2 3 4 5

0 0 0 0=disable (channel selection is not in use)

0 0 1 0=ch 2

0 1 0 0=ch 4

0 1 1 0=ch 6

1 0 0 0=ch 8

1 0 1 0=ch 10

0 0 0 1=ch 1

0 0 1 1=ch 3

0 1 0 1=ch 5

0 1 1 1=ch 7

1 0 0 1=ch 9

NOTE1!

Check, that both MINI-LINKs are set to the same channel before turning the power ON.
New channel is activated when the power is turned ON.

NOTE2! The MINI-LINK unit will not operate with these settings:

1011, 1100, 1101, 1110 or 1111. The power ON indicator starts to blink in case any of these settings has been chosen.

ADDRESS/ CHANNEL/DE-SM

7 DE Delayed alarm

- o Immediate / Delayed Alarm

In case of a failure in the transmission, the alarm output response can be selected from immediate alarm to 10 seconds delayed alarm.

8 SM Safe Mode

- o Unchanged output state / Safe Mode state

In case a failure in transmission, the outputs can be set to remain their status (unchanged) or change to "Safe Mode" which will switch all outputs to OFF-position. Safe Mode timing follows the setting of the switch 7 DE, so it can be immediate or delayed by 10 seconds.

Selection table of the Dip-switches 7 and 8

7DE 8SM

0	0 = Immediate Alarm / No Safe Mode
0	1 = Immediate Alarm / Immediate Safe Mode
1	0 = Alarm delayed by 10 seconds / No Safe Mode
1	1 = Alarm delayed by 10 seconds / Safe Mode delayed by 10 seconds

6 Selecting of the transmission standard

According to the European standard for free channel operation, the ratio of the transmission cycle must not be more than 10/90. This is active when the DIP-switch number 6 is 0. In position 1 the cycle is faster.

Selection table of the DIP-switch number 6

0	= one transmission cycle per second
1	= 3 transmission cycles per second.

4 OPERATION

The Operation mode is selected using the **PRTCL**-switch. The operations are Point-to-Point or Point-to-Multipoint. In Point-to-Point operation mode the system consists of one pair of units. The inputs of the unit are transmitted as outputs of the other unit. In Multipoint mode the main-station controls the sub-stations.

4.1 Point- to-Point

Point-to-Point operation is between two units. The inputs of the unit are transmitted as outputs of the other unit.

4.1.1 Updating Digital messages

Digital information (relay, switch etc.) will be sent to the other unit always, when there is a change at the input.

4.1.2 Start of the Point-to-Point operation

- Connect SATELLINE-1870 radio modem to MINI-LINK directly to its connector and check that it is locked.
- The MP-switch must be "0", in the P-to-P-position.
- Before connecting the device to a power supply, connect first all inputs and outputs that are to be used.
- When both units have these basic settings the supply voltage can be connected.
- Check that the channel switches 2, 3, 4, 5 = 0000, unless they are purposely selected for a specific channel for example 2, 3, 4, 5 = 0101 = channel 5 (see chapter 3.7... /channel selection table).



4.2 Point-to-Multipoint

In this mode the program at the main station controls the units of the sub stations. The main station can drive one or more sub stations (maximum 15 pcs / system).

4.2.1 Start of the Multipoint operation

- Connect one SATELLINE radio modem to the COM-Port of the PC.
- Connect the MINI-LINK slave(s) to the SATELLINE-1870 radio modems.
- The "MP"- switch must be "1", in the P-to-MP-position.
- Before connecting the device to a power supply, connect first all inputs and outputs that are to be used.
- Set individual **address** to all slaves. (As this is a master-slave operation, the slaves have to be addressed). All slaves must have different address (see chapter 3.7.../address selection table).
- Start using the system by the master by opening the controlling program for example SATELLINK PC Pro etc.
- With the program it is possible to turn ON / OFF the outputs and monitor the inputs.

Please contact local SATEL distributor or visit SATEL's web site in order to get information of the multipoint commands.

5 FACTORY SETTINGS

The MINI-LINK I/O -converter is shipped with the following default settings (unless specifically ordered with settings other than those listed below):

FIXED SETTINGS DEFINED AT THE TIME OF ORDER		
PM, protocol switch, P-to-P or Multipoint	0	= Point-to-Point
ADDRESS/CHANNEL	0000	= No address
Transmission cycle	0	= 1/sec (European std.)
DE, Alarm delay	0	= No Delay
SM, Safe mode	0	= No Safe Mode

6 CONNECTION EXAMPLES

Point-to-Multipoint

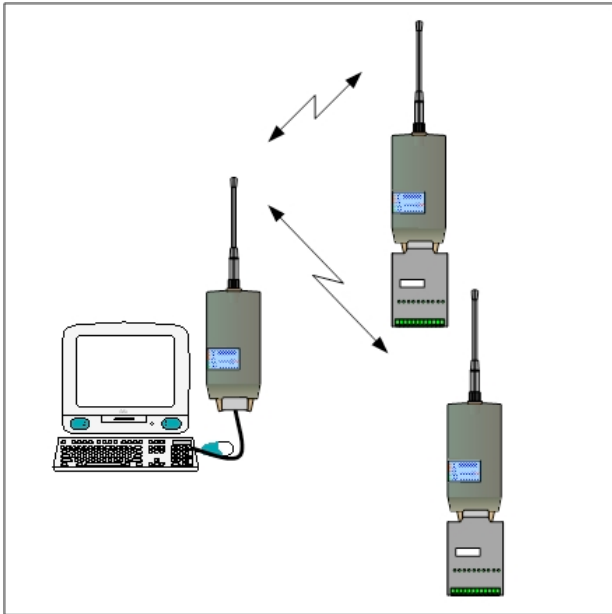

Point-to-Point

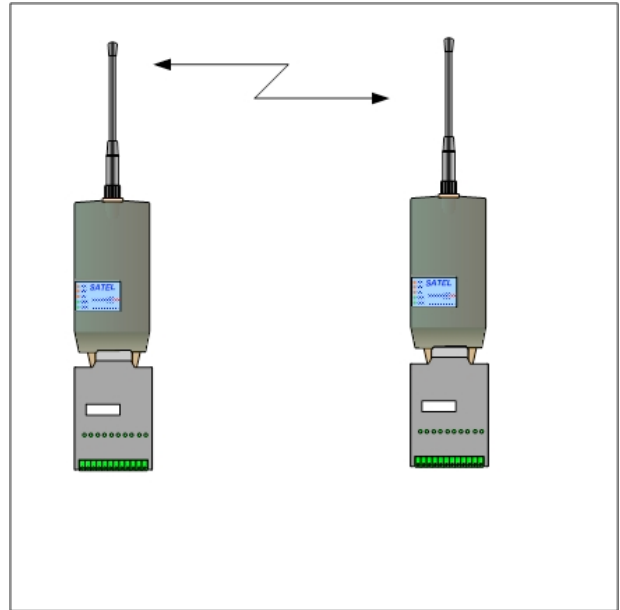

Opening of the Radio
modem's lock pins with
a screw driver

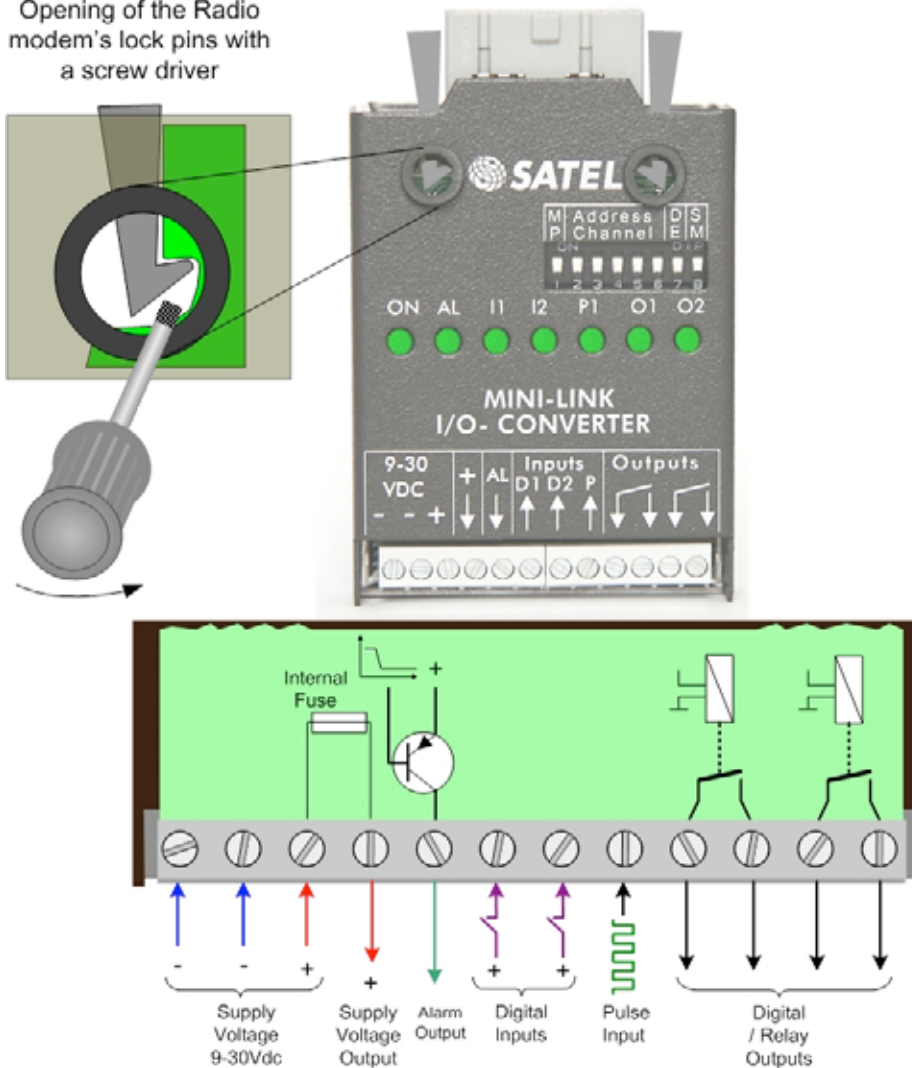

7 ACCESSORIES

SATELLINK PC and SATELLINK PC Pro

Programs that make it possible to operate a Multipoint system with a PC.

Layout of the **SATELLINK PC Pro** Multipoint-program

