



citadel™

CITADEL CTD-NV

Robust, Reliable, and Rugged CTD

High-accuracy Conductivity, Temperature, and Depth with External Input, Direct Digital Output, and Datalogging Capability

The Citadel CTD-NV provides scientific-quality conductivity, temperature and depth measurement capability in an extremely rugged package. This new CTD utilizes the patented Non-eXternal Inductive Cell (NXIC) conductivity sensor, and represents a new generation of extremely durable precision measurement instruments.

The Citadel CTD-NV is a fast sampling, fully integrated instrument platform with optional battery power, datalogging and external analog sensor input. Its flow-thru design excels in rapid profiling and towing applications or mounting to AUV's and ROV's.

The Citadel CTD-NV's NXIC internal conductivity cells do not suffer from proximity effects as do typical external inductive cells, and allow the unit to be mounted in virtually any orientation, close to other equipment. The unit draws very low power and can run for 400 hours continuous on its 3 V battery pack. The instrument also does not need to be calibrated yearly, and can be field cleaned without affecting factory calibration. There are no pumps or fragile electrodes to ensure reliability in demanding marine environments.



The Citadel CTD-NV offers:

- High accuracy
 ± 0.0002 S/M conductivity
 $\pm 0.005^\circ\text{C}$ temperature
 0.08% full scale pressure
- Salinity calculation using PSS-78
- Sound velocity calculation using UNESCO 44
- Non-external inductive conductivity sensor with no electrodes to foul
- No pump required
- Rugged thermistor
- Silicon pressure sensor
- Built-in real-time clock
- Direct digital output via RS-232, RS-485 or CMOS
- Windows® software for system configuration, data acquisition, real-time

TELEDYNE
RD INSTRUMENTS

A Teledyne Technologies Company



ROBUST, RELIABLE, AND RUGGED CITADEL CTD'S



Technical Specifications

Sensors

Parameter	Conductivity	Temperature	Pressure
Sensor	Inductive Cell	Thermistor	Precision-machined Silicon
Range	0- 9.0 S/m (0-90 mS/cm)	-5 to 45°C	Customer specified
Accuracy	±0.0002 S/m (±0.002 mS/cm)	±0.005°C*	0.08% full scale*
Stability	±0.0005 mS/cm/month	0.0005° C/month	±0.004%
Resolution	0.00001 S/m (0.0001 mS/cm)	0.001°C	0.001% full scale
Response	5.0 cm at 1 m/sec flow	100 msec	25 msec

Instrument

Power:	8 to 35 VDC @ 40 mA
Physical:	500m Delrin housing standard 7000m titanium housing optional
Sample Rate:	User Programmable from 1 to 15 Hz
Resolution:	20 bits
Real-time Clock:	Programmable Alarm/Sleep Functions ±20 ppm/year, ±5 ppm/year optional
Data Format:	Baud Rates: 1.2, 9.6, 19.2, 38.4, 57.6, 115 kbps (Data Bits: 8 Stop bits: 1)
Format:	ASCII Protocol: RS-232 or RS-485, or CMOS
Warm-up:	3.0 seconds after power up
Battery Options:	Welded Alkaline

Dimensions (CTD-NV Direct Read)

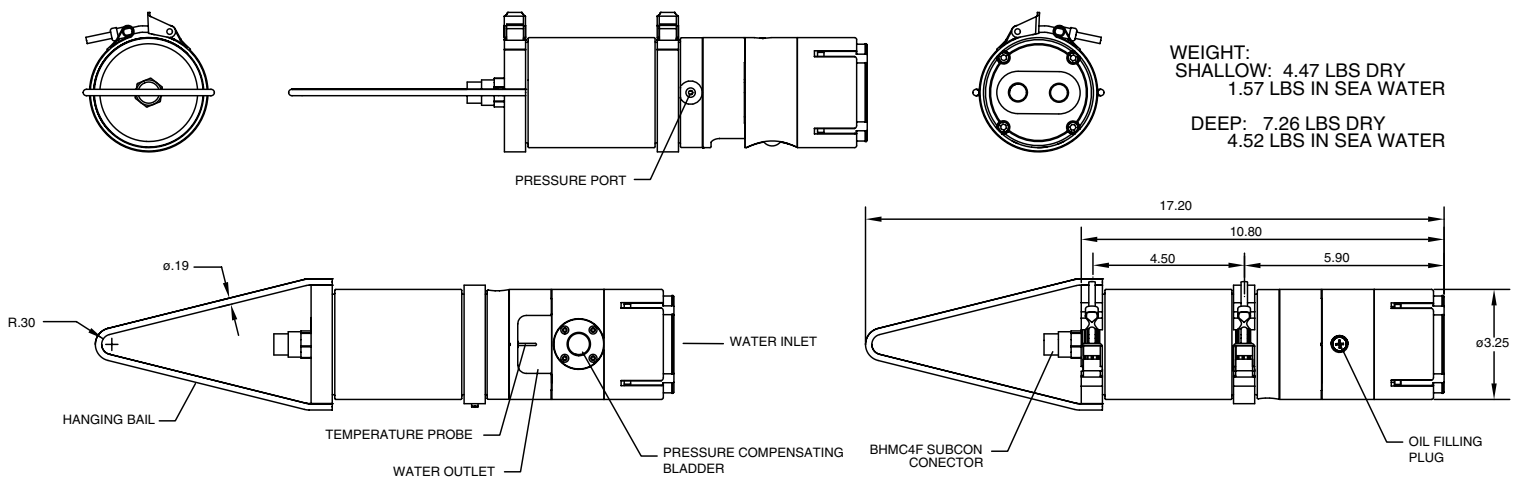

WEIGHT:
SHALLOW: 4.47 LBS DRY
1.57 LBS IN SEA WATER
DEEP: 7.26 LBS DRY
4.52 LBS IN SEA WATER

All dimensions are in inches. All dimensions are subject to change.